

**Sears**

**MODEL NO.  
917.253110**

# **OWNER'S MANUAL**

**Assembly  
Operation**

**Maintenance  
Repair Parts**

*Bought 1979*

## **MANUAL**

## **3-POINT HITCH**

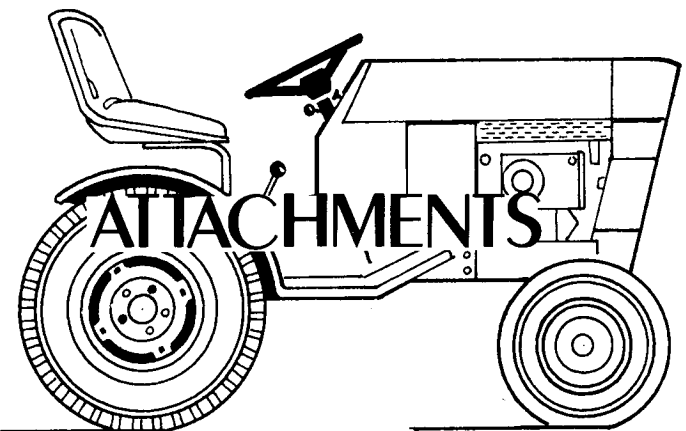

# TABLE OF CONTENTS

ASSEMBLY INSTRUCTIONS . . . . .	1	MAINTENANCE INSTRUCTIONS . . . . .	4
OPERATION INSTRUCTIONS . . . . .	4	REPAIR PARTS . . . . .	5

## RULES FOR SAFE OPERATION

1. Know the controls and how to stop quickly. READ THE OWNER'S MANUAL.
2. Do not allow children to operate the vehicle. Do not allow adults to operate it without proper instruction.
3. Do not carry passengers. Keep children and pets a safe distance away.
4. Always wear substantial footwear. Do not wear loose fitting clothing that could get caught in moving parts.
5. Keep your eyes and mind on your tractor, mower and the area being cut. Don't let other interests distract you.
6. Do not attempt to operate your tractor or mower when not in drivers seat.
7. Always get on or off your tractor from the operators left hand side.
8. Clear the work area of objects which might be picked up and thrown.
9. Disengage all attachment clutches and shift into neutral before attempting to start the engine.
10. Disengage power to attachments and stop the engine before leaving the operator's position.
11. Disengage power to mower, stop the engine and disconnect spark plug wire(s) from spark plug(s) before cleaning, making an adjustment or repairs.
12. Disengage power to attachments when transporting or not in use. Drive slowly when rear mounted attachment is in transport position.
13. Take all possible precautions when leaving the vehicle unattended, such as disengaging the power-take-off, lowering the attachments, shifting into neutral, setting the parking brake, stopping the engine, and removing the key.
14. Do not stop or start suddenly when going uphill or downhill. Mow up and down the face of slopes (not greater than 15°); never across the face.
15. Reduce speed on slopes and make turns gradually to prevent tipping or loss of control. Exercise extreme caution when changing direction on slopes.
16. Do not shift gears while going up or down slopes. Choose a gear low enough to negotiate the slope without stopping and shifting gears. To reduce speed, move throttle lever to slow.
17. Never mow in wet or slippery grass, when traction is unsure or at a speed which could cause a skid.
18. Stay alert for holes in the terrain and other hidden hazards.
19. Do not drive too close to creeks, ditches and public highways.
20. Exercise special care when mowing around fixed objects in order to prevent the blades from striking them. Never deliberately run tractor or mower into or over any foreign object.
21. Never shift gears until tractor comes to a stop.
22. Never place hands or feet under the mower, in the deflector (discharge chute) or near any moving parts while tractor or mower are running. Always keep clear of discharge chute.
23. Use care when pulling loads or using heavy equipment.
  - a. Use only approved drawbar hitch points.
  - b. Limit loads to those you can safely control.
  - c. Do not turn sharply. Use care when backing.
  - d. Use counterweights or wheel weights when suggested in this owner's manual.
24. Watch out for traffic when crossing or near roadways.
25. When using any attachments, never direct discharge of material toward bystanders nor allow anyone near the vehicle while in operation.
26. Handle gasoline with care - it is highly flammable.
  - a. Use approved gasoline containers.
  - b. Never remove the cap of the fuel tank or add gasoline to a running or hot engine, or fill the fuel tank indoors. Wipe up spilled gasoline.
  - c. Open doors if the engine is run in the garage - exhaust fumes are dangerous. Do not run the engine indoors.
27. Keep the vehicle and attachments in good operating condition, and keep safety devices in place. When using Three Point Hitch remove attachment from hitch before making any repairs on attachment or hitch.
28. Keep all nuts, bolts and screws tight, all cotter pins and retainer springs in place to be sure the equipment is in safe working condition.
29. Never store the equipment with gasoline in the tank inside a building where fumes may reach an open flame or spark. Allow the engine to cool before storing in any enclosure.
30. To reduce fire hazard, keep the engine free of grass, leaves or excessive grease.
31. The vehicle and attachments should be stopped and inspected for damage after striking a foreign object, and the damage should be repaired before restarting and operating the equipment.
32. Do not change the engine governor settings or overspeed the engine.
33. When using the vehicle with mower, proceed as follows:
  - a. Mow only in daylight or in good artificial light.
  - b. Never make a cutting height adjustment while the engine is running if the operator must dismount to do so.
  - c. Shut the engine off when removing the grass catcher or unclogging chute.
  - d. Check the blade mounting bolts for proper tightness at frequent intervals.
34. Check the grass catcher bags frequently for wear or deterioration. Replace with new bags for safety protection.



**LOOK FOR THIS SYMBOL TO POINT OUT IMPORTANT SAFETY PRECAUTIONS. IT MEANS-ATTENTION! BECOME ALERT! YOUR SAFETY IS INVOLVED.**

**To assemble your Hitch you will need:**

- (1) Pliers
- (2) 11/16" Wrenches
- (1) 3/4" Wrench
- (1) Ruler

When R.H. (Right Hand) or L.H. (Left Hand) is used, it means from a position behind the steering wheel as if you were seated on the tractor seat and facing forward.

**ASSEMBLY**

**IF YOUR TRACTOR TAILLIGHT AND DRAWBAR LOOK LIKE THOSE SHOWN IN FIGURE 1 BEGIN ASSEMBLY WITH STEP 1.**

**IF YOUR TRACTOR REAR REFLECTOR AND DRAWBAR LOOK LIKE THOSE SHOWN IN FIGURE 3 BEGIN ASSEMBLY WITH STEP 6.**

1. Install Lower Link Pin using:

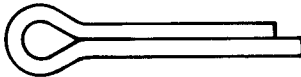

- two Cotter Pins found in bag of parts.
- a. Slip Lower Link Pin through holes in sides of Tractor Drawbar by inserting Pin through opening between web and rim of wheel. In some cases it may be necessary to remove one wheel (Fig. 1).
- b. Insert and spread Cotter Pins through inner holes of Lower Link Pin (underneath Drawbar).

2. Assemble Attaching Plate to Tractor Drawbar using:

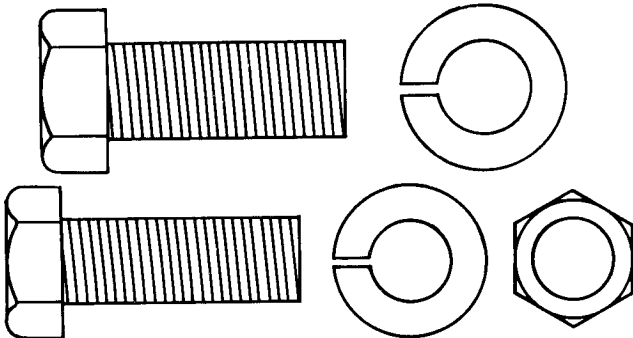

two (1/2 x 1 - 1/4) Hex Bolts, two Lockwashers (1/2"), two (7/16 x 1 - 1/4) Hex Bolts, two Lockwashers (7/16"), and two Hex Nuts (7/16") found in bag of parts.

- a. Using the two upper holes (A) in Attaching Plate and Tractor Drawbar, loosely assemble Plate to Drawbar using two (1/2") Hex Bolts and Lockwashers (Fig. 2). Lockwashers must be next to heads of Bolts. Drawbar has nuts secured to underside.
- b. Using the two lower holes (B) in Attaching Plate and Drawbar, assemble Plate to Drawbar using two (7/16") Hex Bolts, Lockwashers and Hex Nuts. Tighten all four Bolts securely.

3. Assemble Lower Hitch Bars using:

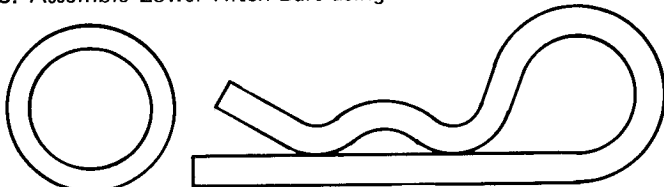

two Spacers and two Retainer Springs found in bag of parts.

- a. Assemble a Lower Hitch Bar over the R.H. end of the Lower Link Pin (Fig. 2). Decals on Lower Hitch Bars show correct positioning.
- b. Place a Spacer over the Lower Link Pin and secure with a Retainer Spring.
- c. Repeat steps a and b for L.H. side.

4. Assemble Chains, Rings and Retainer Springs to Lower Hitch Bar using:

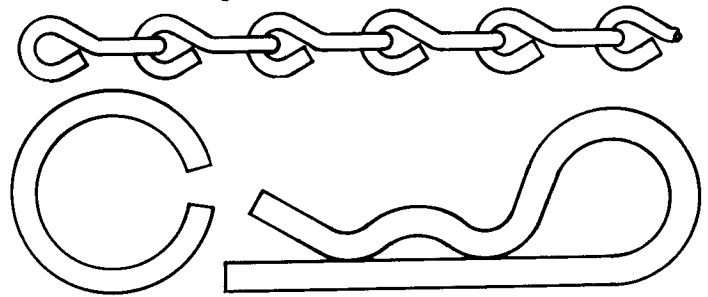

two Chains, two Rings and two Retainer Springs found in bag of parts.

- a. Place Chain through hole (D) in Lower Hitch Bar-R.H. side (Fig. 2).
- b. Place a Retainer Spring on Ring.
- c. Position the two end links of Chain over Ring and squeeze Ring tightly to secure Chain and Retainer Spring.
- d. Repeat steps a, b and c for L.H. side.

5. Finish Hitch Assembly for your tractor with Steps 11 through 13, page 3.

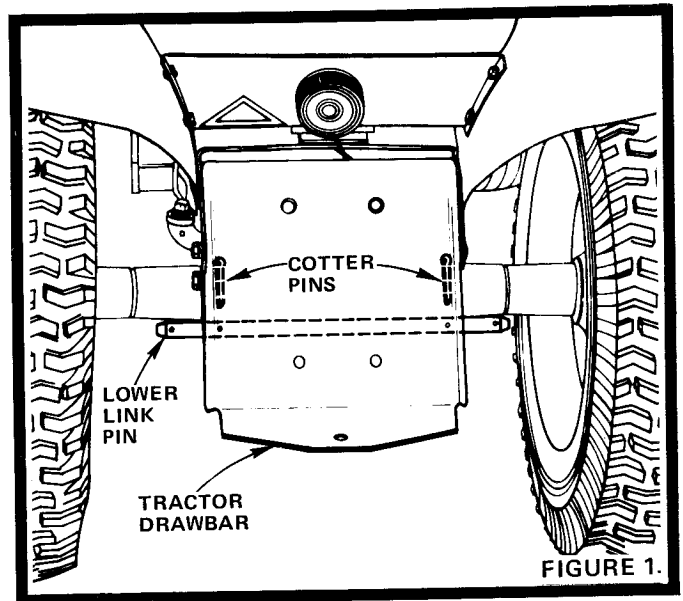

FIGURE 1.

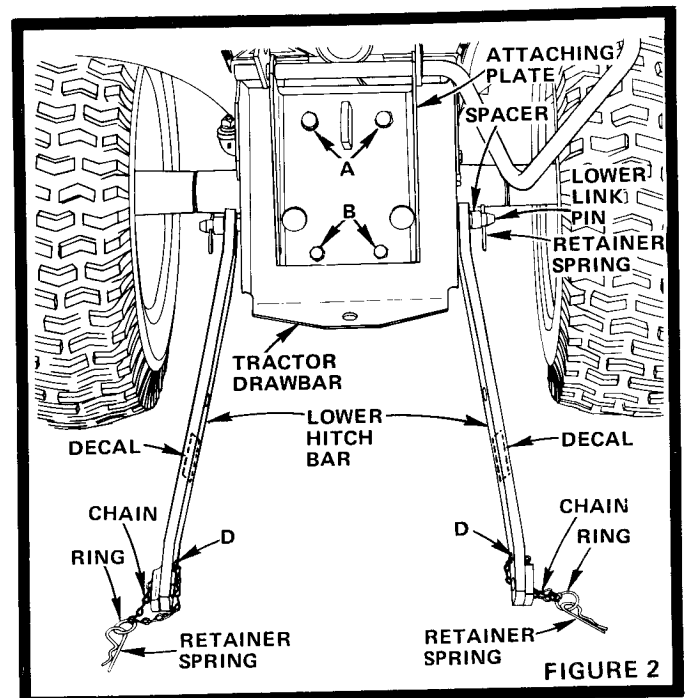
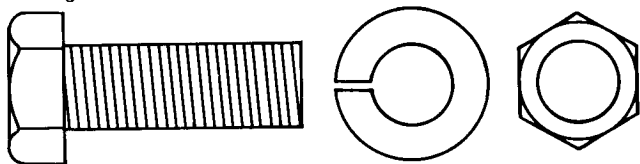

FIGURE 2

## ASSEMBLY-ALTERNATE

IF YOUR TRACTOR REAR REFLECTOR AND DRAWBAR LOOK LIKE THOSE IN FIGURE 3 BEGIN ASSEMBLY WITH STEP 6.

6. Assemble Lower Hitch Bar Bracket to Tractor Drawbar using:



two (7/16 x 1 - 1/4) Hex Bolts, two Lockwashers (7/16"), and two Hex Nuts (7/16").

- Position Lower Hitch Bar Bracket to underside of Tractor Drawbar as shown in Fig. 3.
- Secure Bracket to Drawbar with two Hex Bolts, two Lockwashers and two Hex Nuts. Tighten Nuts securely.

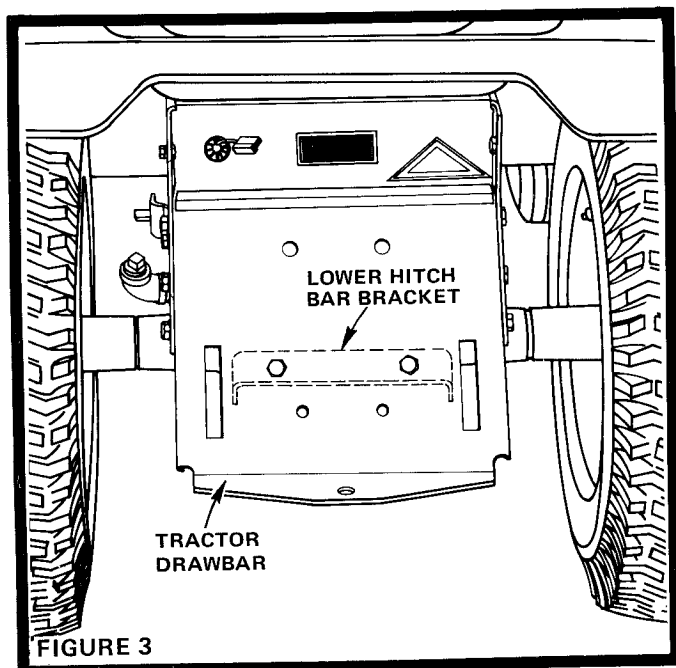

FIGURE 3

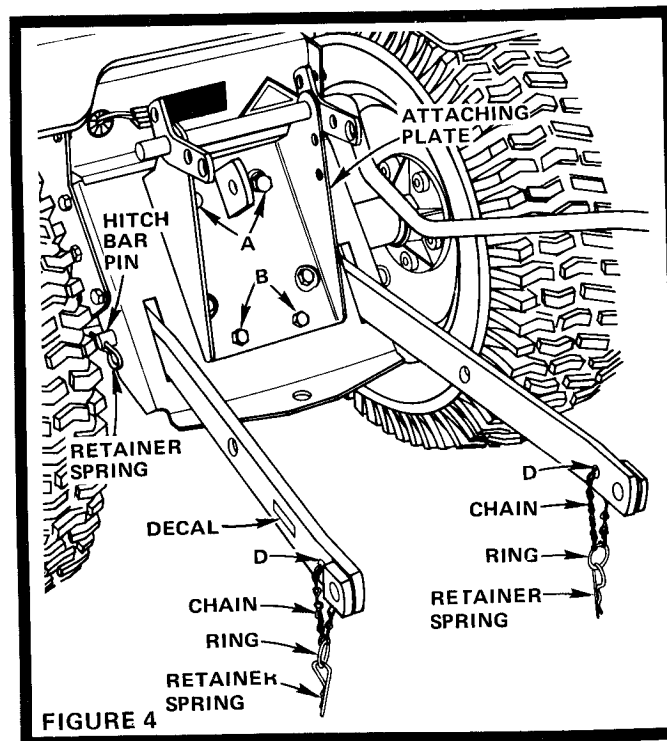
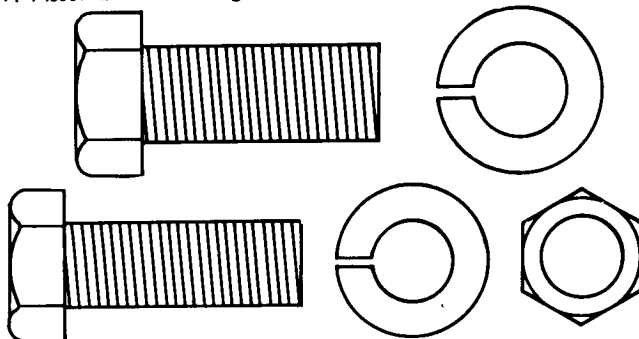

FIGURE 4

7. Assemble Attaching Plate to Drawbar using:



two (1/2 x 1 - 1/4) Hex Bolts, two Lockwashers (1/2") two (7/16 x 1 - 1/4) Hex Bolts, two Lockwashers (7/16"), and two Hex Nuts (7/16") found in bag of parts.

- Using the two upper holes (A) in Attaching Plate and Tractor Drawbar, loosely assemble Plate to Drawbar using two (1/2") Hex Bolts and Lockwashers (Fig. 4). Lockwashers must be next to heads of Bolts. Drawbar has nuts secured to underside.
- Using the two lower holes (B) in Attaching Plate and Drawbar, assemble Plate to Drawbar using two (7/16") Hex Bolts, Lockwashers and Hex Nuts. Tighten all four Bolts securely.

8. Assemble Lower Hitch Bars using:

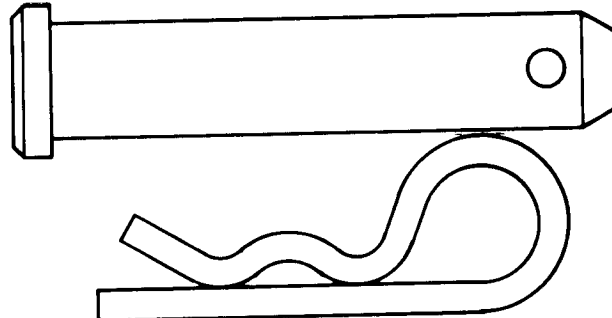

two Hitch Bar Pins and two Retainer Springs.

- Slip a Lower Hitch Bar through slot in Tractor Drawbar (Fig. 4). Decals on Lower Hitch Bars show correct positioning.
- Place a Hitch Bar Pin through hole in Lower Hitch Bar Bracket. Line up hole in Lower Hitch Bar with hole in Tractor Drawbar. Slide Hitch Bar Pin through hole in Lower Hitch Bar and Tractor Drawbar.
- Secure by inserting a Retainer Spring through hole in Hitch Bar Pin.
- Follow the above steps for opposite side.

9. Assemble Chains, Rings and Retainer Springs to Lower Hitch Bars using:

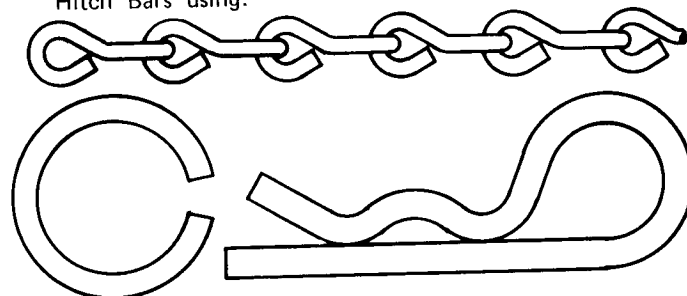

two Chains, two Rings and two Retainer Springs found in bag of parts.

- Place Chain through hole (D) in Lower Hitch Bar-R.H. side (Fig. 4).
- Place a Retainer Spring on Ring.
- Position the two end links of Chain over Ring and squeeze Ring tightly to secure Chain and Retainer Spring.
- Repeat steps a, b and c for L.H. side.

10. Finish Hitch Assembly for your tractor with Steps 11 through 13, page 3.

# ASSEMBLY-COMPLETION

## FOR ALL TRACTORS

### 11. Assemble Lift Links using:

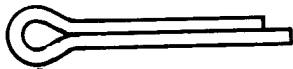

four Cotter Pins found in bag of parts.  
LEFT HAND SIDE:

- a. Assemble Lift Link-L.H. to Lift Arm. Position with bend up and Link in outer hole of Lift Arm as shown in Fig. 5. Secure with Cotter Pin.
- b. Assemble opposite end of Lift Link-L.H. to lower Hitch Bar. Secure with Cotter Pin.

### RIGHT HAND SIDE:

- a. The Right Hand Lift Link Assembly was adjusted at the factory to 11 - 3/8 inches center to center of Lift Link ends (Fig. 5). Check this dimension and adjust if necessary by loosening Locknut and adjusting Turnbuckle equally on Upper and Lower Lift Links. Tighten Locknut against Turnbuckle.
- b. Insert Upper Lift Link (with bend) into outer hole of Lift Arm. Secure with Cotter Pin.
- c. Insert Lower Lift Link into hole of Lower Hitch Bar as shown. Secure with Cotter Pin.

### 12. Assemble Clevises and Pins using:

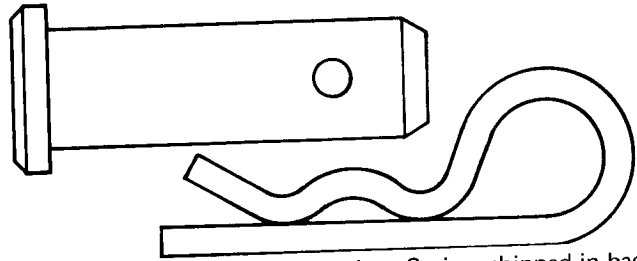

two Clevis Pins and two Retainer Springs shipped in bag of parts.

- a. Clevises were adjusted at the factory to 11 - 3/8 inches from hole center to hole center. Check this dimension and adjust if necessary by turning Clevises equally on Adjusting Screw. NOTE: It may be necessary to loosen Adjusting Screw Locknut. Tighten Locknut against Clevis after adjustment.
- b. Secure Tractor Clevis-R.H. (with flat up) to Bracket with a Clevis Pin. Secure with a Retainer Spring.
- c. Place the other Clevis Pin into Attachment Clevis-L.H. and secure with Retainer Spring.

### 13. Assemble Transport Pin in storage position using:

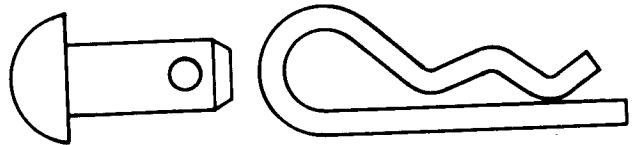

one Transport Pin and one Retainer Spring.

- a. Assemble Transport Pin in hole in R.H. side of Attaching Plate (Fig. 5).
- b. Secure Pin with Retainer Spring.

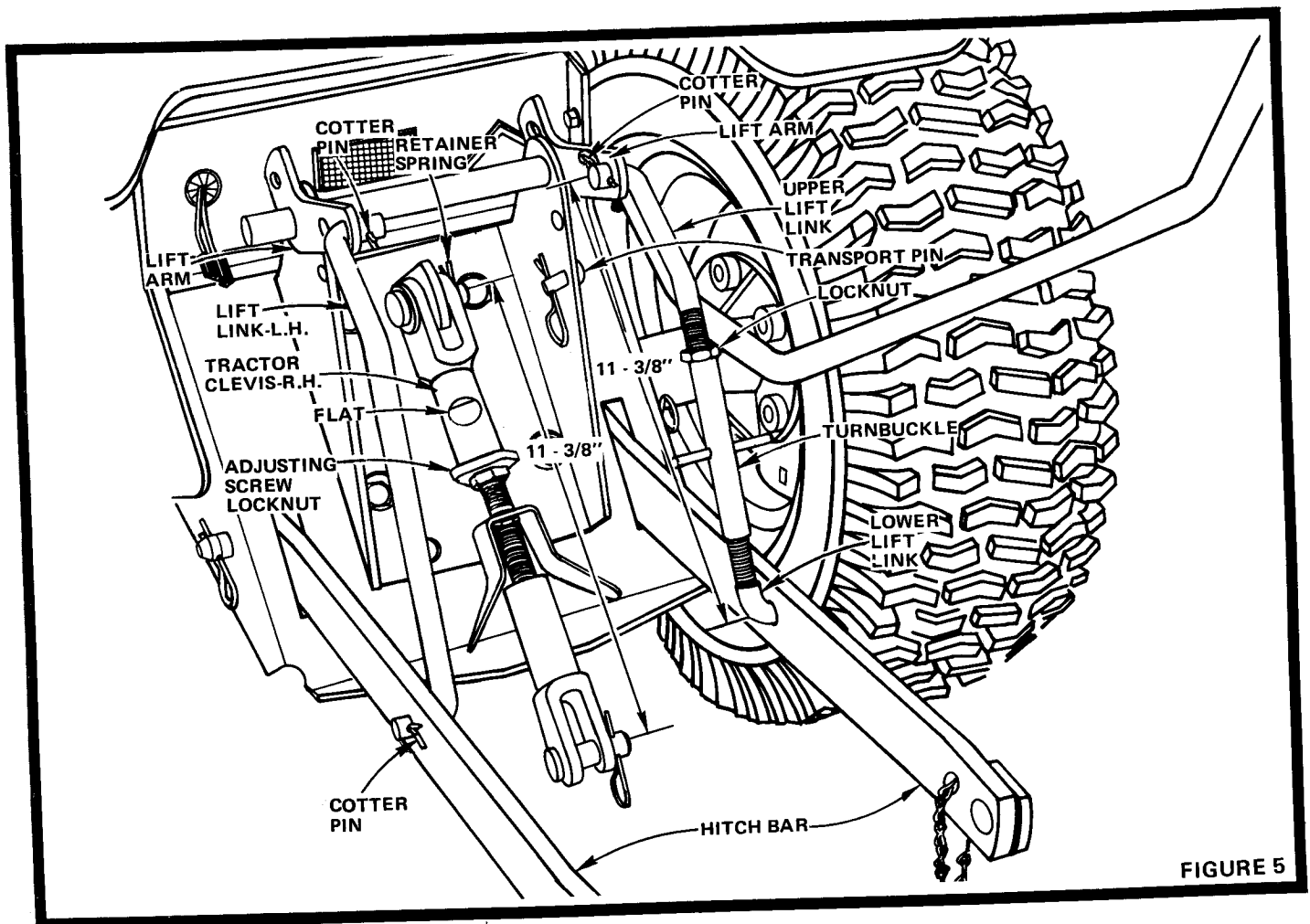

FIGURE 5

## ASSEMBLE ATTACHMENT TO HITCH

Figure 6 illustrates a typical attachment mounting at points A, B and C. Instructions are given in each attachment Owners Manual for particular mounting procedures.

### PLOW ADAPTATION

In order to use a Plow with your Manual 3-Point Hitch the Plow Hitch Bracket must be to the right of the Plow Beam and Coulter Bracket (Fig. 6).

### ROTO-TILLER ADAPTATION

If your Roto-Tiller has a Limit Chain on the R.H. Floating Lift Link to prevent Lift Lever from striking rear tire, do not use the Lever Stop Bracket (Fig. 7) shipped in 3-Point Hitch Bag of Parts.

All other model Roto-Tillers have a Lever Stop Bracket (Fig. 7). You must use the Lever Stop Bracket (with 4 square holes) shipped in 3-Point Hitch Bag of Parts. Follow steps 1 thru 5.

1. Remove Lift Links and set aside to use with other attachments.
2. Assemble Lever Stop to Lever Stop Bracket (Fig. 7) using:

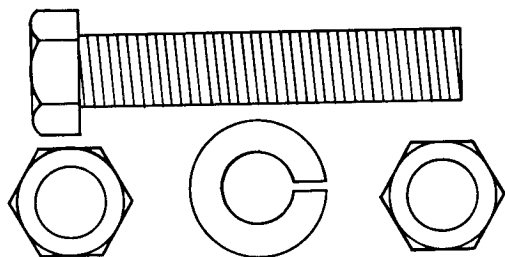

(3/8 x 2) Hex Bolt, two Hex Nuts and Lockwasher found in Roto-Tiller Bag of Parts.

3. Assemble Lever Stop Bracket to Lift Arm using:

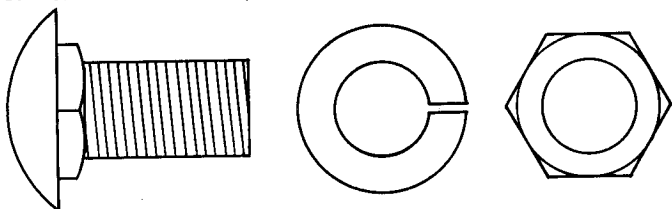

(1/2 x 1) Carriage Bolt, Lockwasher and Hex Nut found in Roto-Tiller Bag of Parts.

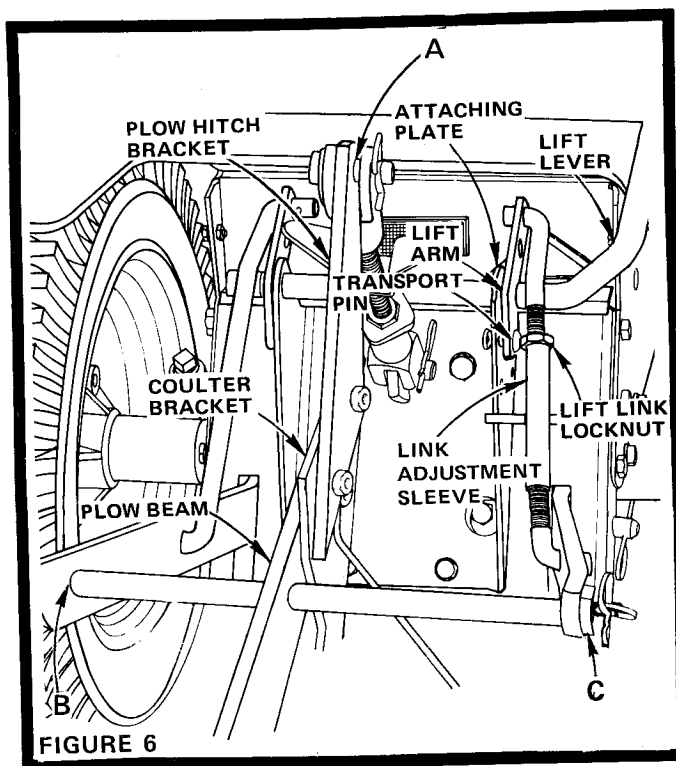

FIGURE 6

- a. 8 H.P. ROTO-TILLER use outer holes in Lift Arm and Lever Stop Bracket (Fig. 7).
  - b. 6 H.P. ROTO-TILLER use inner holes in Lift Arms and Lever Stop Bracket.
4. Use Floating Lift Links furnished with your Tiller.
    - a. 8 H.P. ROTO-TILLER use inner holes in Lift Arm and Lever Stop Bracket (Fig. 7).
    - b. 6 H.P. ROTO-TILLER use outer holes in Lift Arm and Lever Stop Bracket.
  5. Finish Roto-Tiller Attaching and Lever Stop adjusting according to Roto-Tiller Owners Manual.

## ADJUSTMENTS

Instructions are given in each attachment Owners Manual pertaining to its own adjustments. However, the two basic adjustments are as follows:

1. Level Attachment from side to side.
  - a. Loosen Lift Link Locknut (Fig. 6). Turn Link Adjustment Sleeve counterclockwise to lengthen linkage. After adjusting, tighten Locknut against Link Adjustment Sleeve.
  - b. With Floating Lift Links (Fig. 7) adjust Lift Link Locknut.
2. Level Attachment from front to rear.
  - a. Loosen Adjusting Screw Locknut.
  - b. Turn Adjusting Screw clockwise to lengthen the top linkage.
  - c. After adjusting, tighten the Adjusting Screw Locknut against the Clevis-R.H. NOTE: This adjustment is also for setting pitch and/or depth of ground working tool.

## INSTRUCTIONS BEFORE OPERATION

1. Make sure all bolts and nuts are tight, cotter pins are spread and retainer springs are secure.
2. In extreme cases the Lift Lever may touch the tractor seat. If this happens the seat must be moved forward.



READ THE "RULES FOR SAFE OPERATION" CAREFULLY BEFORE OPERATING YOUR HITCH.

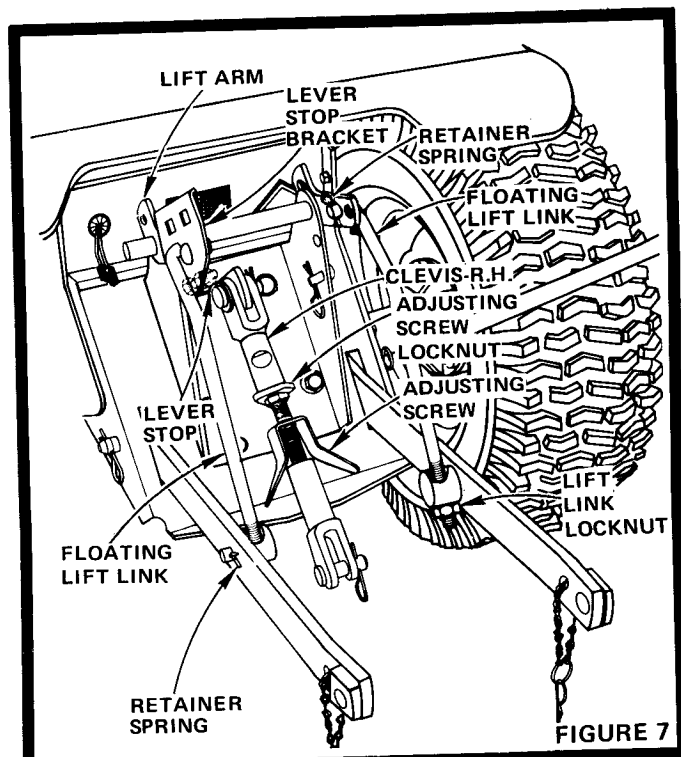

FIGURE 7

## OPERATION



LIFT ATTACHMENT OUT OF THE GROUND WHEN TURNING CORNERS, REVERSING OR TRANSPORTING.

## TO TRANSPORT

1. Remove Retainer Spring and Transport Pin from storage position (Fig. 5).
2. Rotate Lift Lever forward (Fig. 6).
3. Line up hole in Lift Arm of Attaching Plate and Lift Lever with hole in side of Attaching Plate as shown. Insert Transport Pin and secure with Retainer Spring (Fig. 6).



LOCK LIFT LEVER IN UP POSITION BEFORE LEAVING OPERATOR'S POSITION.

## MAINTENANCE

### LUBRICATION

Apply a light coat of grease to threaded areas and pivot points.

### STORAGE

1. Clean and store in a weather proof, dry building.
2. Apply a light coat of grease to threaded areas and pivot points.

Sears, Roebuck and Co. and Simpsons-Sears Limited reserves the right to make any changes in design or improvements without imposing any obligation to install the same upon its items heretofore manufactured.

## REPAIR PARTS

### MANUAL 3-POINT HITCH--MODEL NUMBER 917.253110

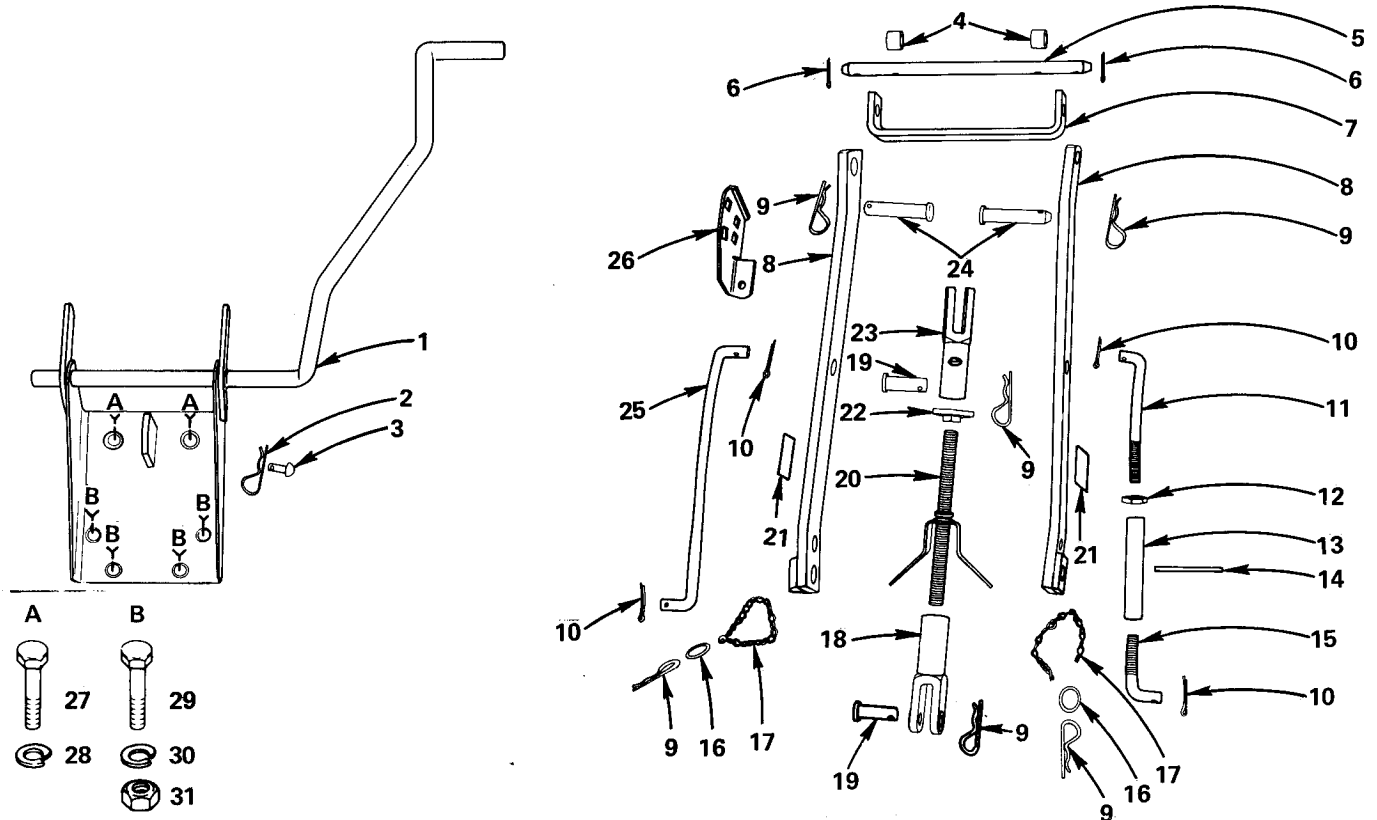

KEY NO.	PART NO.	DESCRIPTION
1	673A44	Attaching Plate and Lift Lever
2	4939M	Retainer Spring
3	8976R	Transport Pin
4	9527R	Spacer
5	1049R	Link Pin Lower
6	2511P	Cotter Pin 3/16 x 1
7	8961R	Lower Hitch Bar Bracket
8	673A41	Lower Hitch Bar and Bushing
9	4940M	Retainer Spring
10	2510P	Cotter Pin 5/32 x 1
11	8950R	Lift Link Upper - R.H.
12	STD541050	*Hex Jam Nut 1/2 - 13 UNC
13	1525H	Link Adjustment Sleeve
14	9710M	Roll Pin
15	8952R	Lift Link Lower - R.H.
16	8986R	Ring
17	8987R	Chain

KEY NO.	PART NO.	DESCRIPTION
18	8936H	Clevis - L.H. Thread
19	8940H	Clevis Pin
20	673A42	Adjusting Screw and Handle
21	6798H	Scotchcal
22	8974R	Adjusting Screw Locknut
23	8975R	Clevis - R.H. Thread
24	8955R	Hitch Bar Pin
25	8954R	Lift Link - L.H.
26	9773R	Lever Stop Bracket
27	STD525012	*Hex Bolt 1/2 - 13 x 1 - 1/4
28	STD551150	*Lockwasher 1/2 Heavy
29	3035P	Hex Bolt 7/16 - 14 x 1 - 1/4
30	STD551143	*Lockwasher 7/16 Heavy
31	STD641443	*Hex Nut 7/16 - 14
---	8995R	Owners Manual

\*STANDARD HARDWARE--PURCHASE LOCALLY

# Sears

**MODEL NO.  
917.253110**

## HOW TO ORDER REPAIR PARTS

### MODEL NUMBER

The Model Number will be found on the Model Plate attached to the R.H. side of the Attaching Plate Weldment. Always mention the Model Number when requesting service or repair parts for your Manual 3-Point Hitch.

### REPAIR PARTS

All parts listed herein may be ordered from any SEARS, ROEBUCK AND CO. or SIMPSONS-SEARS LIMITED retail or catalog store.

WHEN ORDERING REPAIR PARTS, ALWAYS GIVE THE FOLLOWING INFORMATION:

- THE PART NUMBER
- THE PART DESCRIPTION
- THE MODEL NUMBER
- THE NAME OF MERCHANDISE

If the parts you need are not stocked locally, your order will be electronically transmitted to a Sears Repair Parts Distribution Center for "expedited handling".



### SEARS SERVICE

Your Sears merchandise takes on added value when you discover the Sears Service Units throughout the country. Each is staffed by Sears-trained, professional technicians using Sears approved parts and methods.

---

Sears, Roebuck and Co., Chicago, Ill. 60684, U.S.A.  
and Simpsons Sears Limited, Toronto, Canada